



TGF 8900 ERGIT R

SUPERIOR LOW-PROFILE STEERING CAB TRACTOR

Kubota 4 cyl Diesel direct injection Stage 5 Engine 100 Hp • 16+16 Gearbox

Designed for exceptional performance in restricted areas, the TGF 8900 R combines compact dimensions with robust functionality. Its innovative low-profile design and central tunnel free of levers provide unmatched accessibility and driving comfort. The ergonomic layout places all major controls on the right side for ease of use during complex maneuvers. Equipped with a Kubota Stage V engine and synchronized gearbox, it offers smooth and fluid operation across diverse terrains. Safety and efficiency are enhanced by its hydraulic oil-bath disc brakes and a 50-liter fuel tank for extended autonomy.

- **ACTIO™ full chassis with 15° oscillation for constant traction**
- Tyres - 300/80-15.3 front and 360/70 R20 rear (adjustable rims)
- **PTO 540/540e with electrohydraulic engagement**
- Differential lock on rear or both axles with electrohydraulic control
- Multifunctional digital instrumentation and ESC speed control
- Adjustable steering wheel and ergonomic sprung seat with retractable seatbelt.

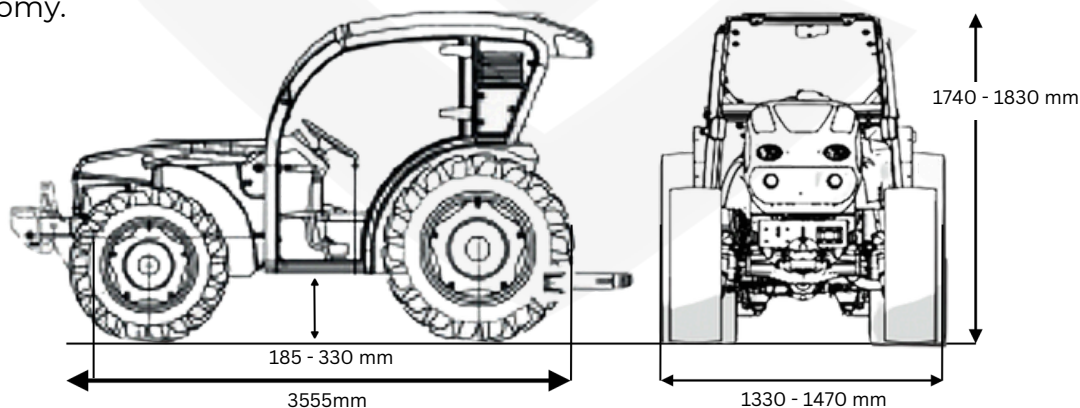

TECHNICAL DATA - TGF 8900 ERGIT R

Description	Value
Engine	KUBOTA · Diesel direct injection with counter rotating weight system · Emissions Regulations: Stage V · N° Cylinders: 4 - 16 Valves · Turbo Displacement (CC): 3769 · Power kW/HP (97/68/CE): 54,6/100 · Maximum engine revs: 2400 (rpm) · Torque max (Nm/revs): 305/1500 · Cooling: Water · Tank Capacity (litres): 50
Transmission	Synchronized 32 speed gear box: 16 forward and 16 reverse with synchronized inverter · Inverter lever Right side · Gear control Right side under the wheel
Chassis	"ACTIOTM" – Full chassis with oscillation · Reversibility RGSTM · Steering wheels · 4 equal wheel drive · Front and rear final drive
PTO (shaft)	Rear, independent 540/540E rpm, synchronised in all gears Oil-immersed multiplate clutch with progressive electro-hydraulic engagement Profile 1" 3/8 with 6 splines with facilitated engagement
Transmission Clutch	Hydraulic control
Hydraulic System	3 double-acting remote valves including 1 float + 1 oil return 2 pumps with independent circuits
Rear hydraulic lift	3-point linkage with Damping function for road transfer FLM and position and draft control (roll bar version) Maximum lift height setting with position and draft control Operating Pressure (bar): 160 · Lifting capacity (Kg): 2400
Steering	Hydraulic steering wheel with through-rod cylinder
Brakes	Hydraulic front/rear oil bath disc brakes; independent hydraulic rear steering brakes Automatic emergency and parking oil bath brakes on transmission
Platform	Suspended on Silent Block
Weight	With roll bar (Kg): 2120÷2370 With Protector cab (Kg/lbs): 2325÷2405
Optional Extras	Extended Warranty (up to 4 years) Bullbar - Front weights - E-Drive transmission - Hydraulic Power Lift with Electronic Control - Dual-Speed Gearbox (540-1000 RPM) - Continuous Delivery & Quick Couplings - Mechanical Lift Control System - ACS (Air Clean System) - Front Hydraulic Power Lift - Towing hook slider narrow type

Price from \$109,950 + GST*

*Tractor Culture reserves the right to adjust pricing based on exchange rate, & shipping cost.

PROTECTOR 100



The Protector 100 is a groundbreaking, pressurized **low-profile cab, standing at just 174 cm in height**. Designed to combine unparalleled comfort, visibility, and safety, it offers the highest protection available on the market as the only compact, Cat. 4-certified pressurized cab. Its **innovative “butterfly” profile steel frame** eliminates projecting elements, ensuring a sleek and aerodynamic design, suspended on Silent Blocks.

The hermetically sealed cab, equipped with the AirControl monitoring system, maintains a safe and healthy environment for operators working with plant protection chemicals. The active carbon filter further guarantees that the air inside the cab is perfectly clean, while the ergonomic controls and rear visibility features enhance both safety and operational ease.

- **Cat. 4-certified** pressurized cab for unmatched operator protection.
- Hermetically sealed cab with **AirControl monitoring system** for safe handling of chemicals.
- **Hydraulic power lift with draft and position control.**
- Ergonomic design with **360° visibility**, including rear window and wheel-inspection windows.
- Features like **pneumatic suspension seat** with adjustable height and automatic weight adaptation (50-130 kg).
- Rear 3-point linkage with adjustable bars and quick couplings for efficient equipment handling.
- **Swinging draw bar** and upgraded tire configurations for enhanced performance.
- Rear working light.
- **Heating & air conditioning system.**

OPTIONAL FEATURES:

- **Radio & Installation \$ 600 + GST**
- **Revers Camera & Installation \$ 900 + GST**
- **Filter CATEGORY4 \$ 900 + GST**
- **Active Carbon filter \$ 600 + GST**

*Tractor Culture reserves the right to adjust pricing based on exchange rate, & shipping cost.

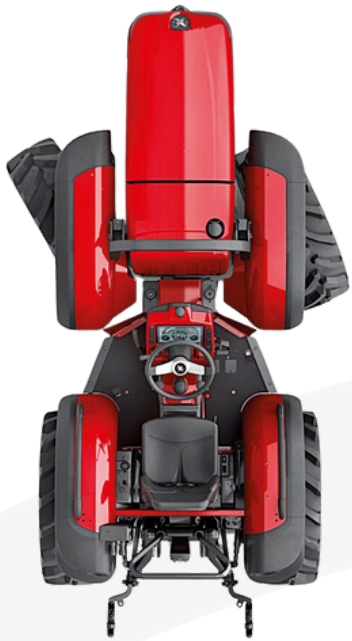

The tractor's **short wheelbase and tight steering radius** provide excellent agility in crop rows. The steering brakes further reduce the turning radius, enhancing the steering effect, which is improved by the double-acting constant velocity joints.

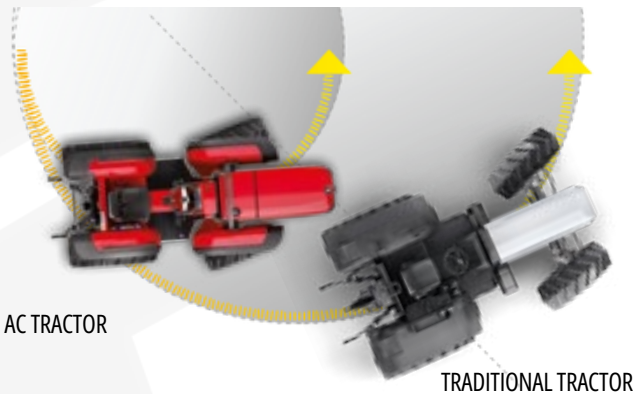

AC TRACTOR

TRADITIONAL TRACTOR

CONTINUOUS FLOW SETTING

Proportional electronic control enables precise adjustment of continuous **oil flow up to 50 L/min**, ensuring optimal hydraulic performance and efficiency.

Comfort

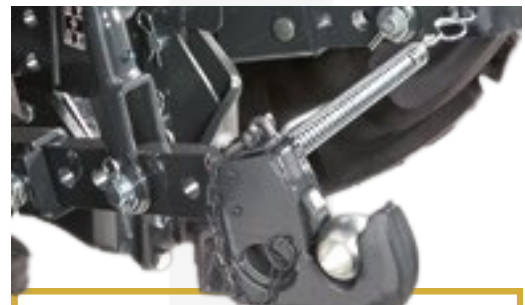

ADJUSTABLE BARS & SWINGING DRAWBAR

Rear 3-point linkage with adjustable bars, quick couplings, and a swinging drawbar for enhanced versatility and ease of use.

The **ACTIO™ Chassis** minimizes operator fatigue by positioning the driver at the tractor's oscillation center, reducing movement during long hours. The intuitive instrumentation includes a backlit display, "on-off" system, digital tachometer, and electro-hydraulic controls.

The **pneumatic suspension seat** offers adjustable height and automatic weight calibration (50–130 kg), ensures optimal comfort for drivers of varying sizes.

TGF 8900



STANDARD WARRANTY



As a proof of its reliability **EXTENDED WARRANTY**



*Optional
\$ 5,550 + GST

DAMPING SYSTEM

Ensures stability at all times by absorbing stresses from mounted implements, enhancing comfort and protecting both the driver and the machine.

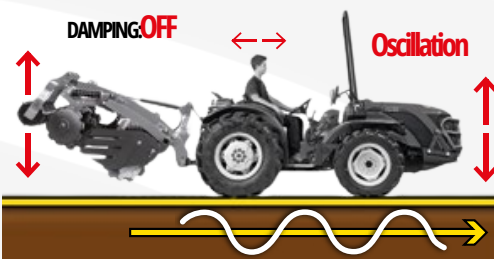

ACTIO™

FULL CHASSIS WITH OSCILLATION
Features a solid cast-iron chassis attached to the axles, housing the tractor transmission. It has a central joint with up to 15° of longitudinal oscillation, ensuring stability and traction as the ends follow terrain contours. This design improves performance, safety, and weight distribution: 60% on the front axle and 40% on the rear.

OPTIONAL FEATURES



BULLBAR

Tubular steel guard protecting the bodywork; integrates the third-point for the front lift.

\$ 1450 + GST



FRONT WEIGHTS

Front weights (3+3, total 132 kg) mounted on the side of the hood – compatible with 24" or 22.5" rear wheels.

\$ 1800 + GST



FRONT HYDRAULIC POWER LIFT

Integrated 3-Point Linkage. Front Hydraulic Outlets – 1 double-acting distributor replicated at the front (2 outlets) - Only with Front Bull Bar.

\$ 3300 + GST

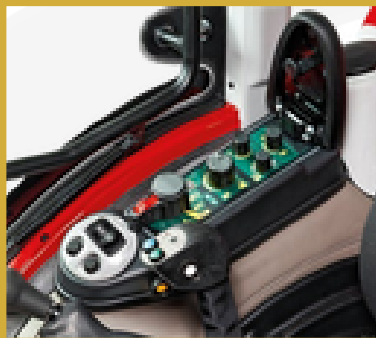

HYDRAULIC POWER LIFT WITH ELECTRONIC CONTROL

- Lever-Control System – Transport, Neutral, and Working modes.
- Additional Hydraulics – Two DA distributors for the 3-point linkage and RH vertical tie-rod, with four ½" quick couplings.
- Electronic Adjustments – Depth, draft/position mix, lift height, and lowering speed.
- Damping Function – Reduces oscillations during road transport.
- Enhanced 3-Point Linkage – Adjustable bars, quick couplings, and a hydraulic third point & RH tie-rod.

\$ 3800

DUAL-SPEED GEARBOX (540-1000 RPM)

Allows switching with a Gearbox w/ PTO 540-1000 RPM.

\$ 1300 + GST

CONTINUOUS DELIVERY & QUICK COUPLINGS

1 draining quick coupling (2 total rear couplings) with Hydraulic Power Lift and Electronic Control.

\$ 1900 + GST

MECHANICAL LIFT CONTROL SYSTEM

3-Point, RH Vertical Tie-Rod & Quick Couplings for mechanical draft control lift

\$ 2300 + GST



ACS (AIR CLEAN SYSTEM)

Engine cooling fan with air flow reversal. Reduces the need for cleaning the front grille, ensuring more constant engine cooling.

\$ 4300 + GST



E-DRIVE TRANSMISSION

With shuttle control on the steering wheel is especially practical when frequent changes of direction are required.

\$ 3050 + GST



TOWING HOOK SLIDER NARROW TYPE

The slider tow hook with rapid vertical adjustment, is used to optimize the connection height of the towed equipment.

\$ 1300 + GST

*Tractor Culture reserves the right to adjust pricing based on exchange rate, & shipping cost.